

Top View of Assembly

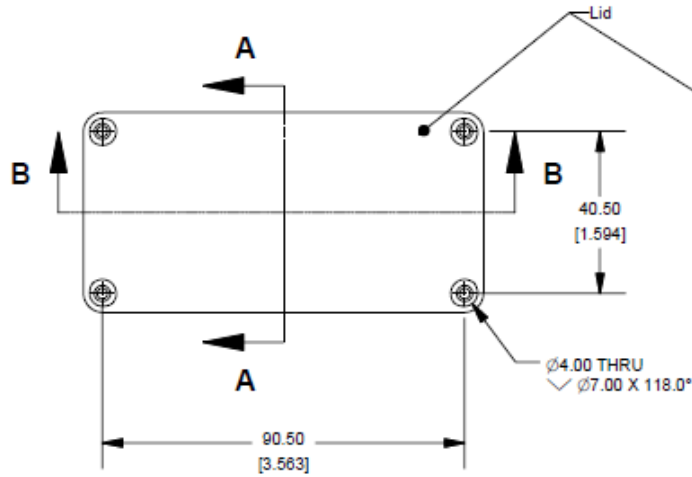

SECTION A-A
End View of Assembly

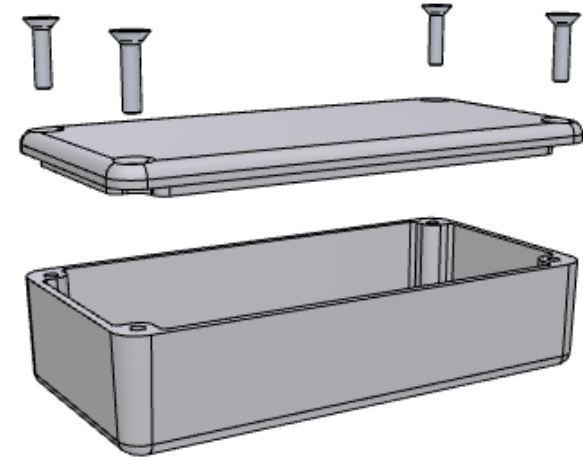
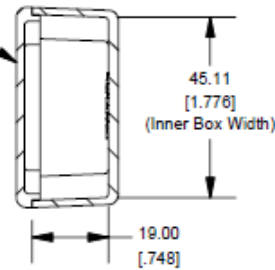

SECTION B-B
Side View of Assembly

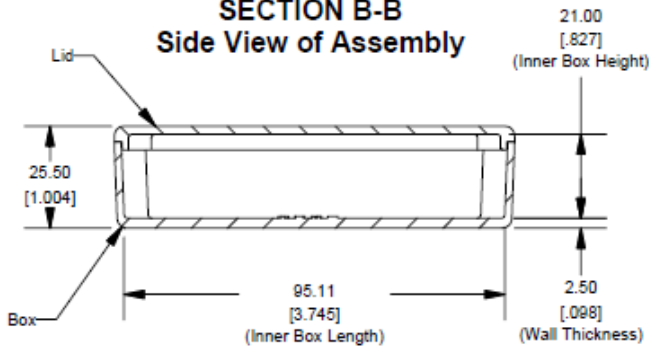

Top View Looking Inside Box

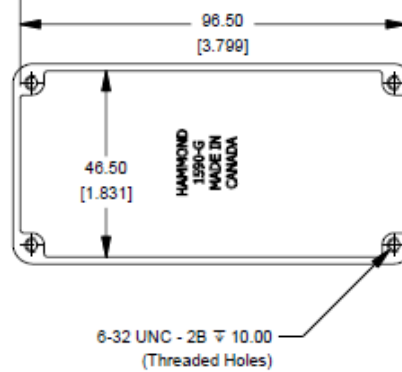

Lid

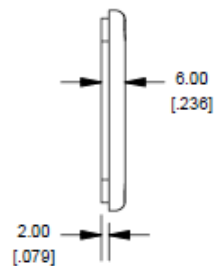
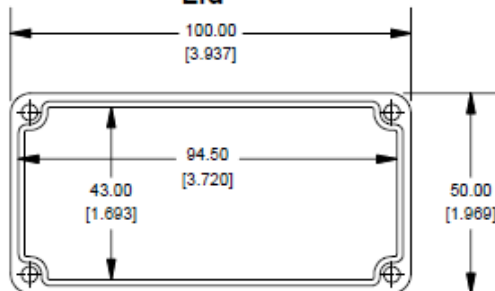

NOTE

Purchased assembly includes box, lid and 4 cover screws.
Box and lid are made from Diecast Aluminum Alloy (alloy type 380).
Silicone Gasket Loctite #5950

PART NUMBERS

1590G Enclosure	
Unfinished	1590G
Grey Textured Polyester Powder Paint - RAL 7038	1590GGY
Black Textured Polyester Powder Paint - RAL 9011	1590GBK
1590G Liquid Resistant Enclosure (Silicon Factory Installed Gasket)	
Unfinished	1590WG
Black Textured Powder Paint	1590WGBK
ACCESSORIES	
Recommended Torque: 75 ozf.in / 55 cN.m	
Black Textured Cover Screws (Pkg 50) [6-32 x 1/2" SS Type 304]	1590WMS100BK
Unfinished Cover Screws (Pkg 100) [6-32 x 1/2" Nickel Plated Screws]	1590WMS100
Standard Cover Screws	
Unfinished Cover Screws (Pkg 100) [6-32 x 1/2" Nickel Plated Screws]	1590MS100
Black Textured Cover Screws (Pkg 50) [6-32 x 1/2" SS Type 304]	1590MS100BK